

# Mobilift 0049

## Accessories



Remote holder



RF Remote



Wheels 2pcs



Wheels with brake 2pcs



Threaded pin

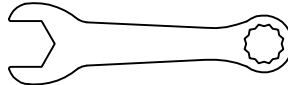

Spanner 17mm

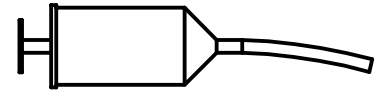

Lubricator

## Important information



**Not for children under 6 years old.**  
All older children can use Lift, only under adult supervision.

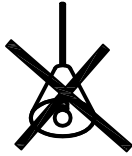

### **WARNING!** Crushing Risk

While using, the space above and below screen must be free.

UP

DOWN

Before using remember to lock wheel brakes.

**LOCK!!!**

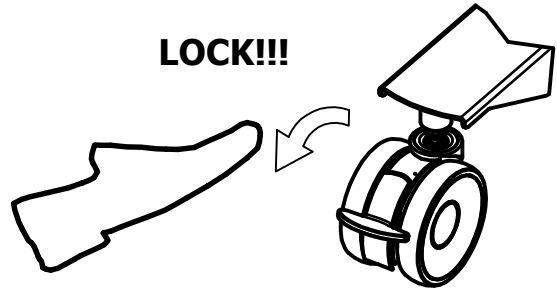

Press UP button to move screen higher.

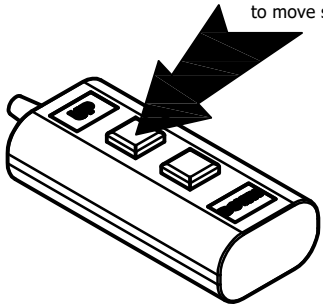

Press DOWN button to move screen lower.

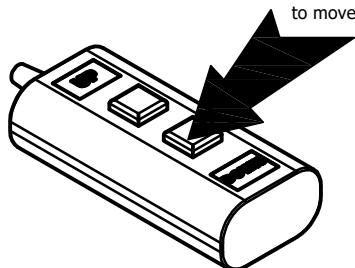

**DON'T  
PUSH**

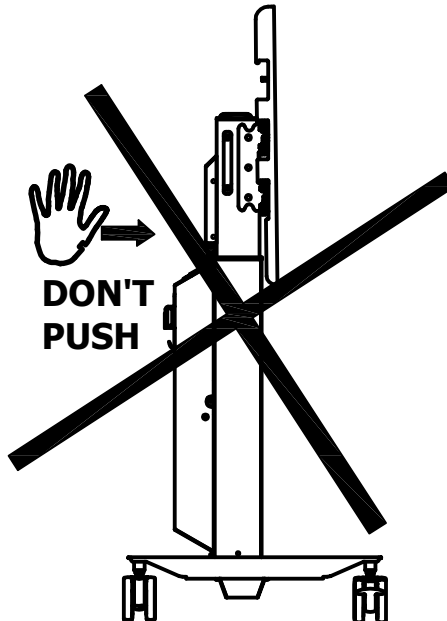

# Max LOAD

**130Kg**



Never Transport while lift is up or there is connected main plug.

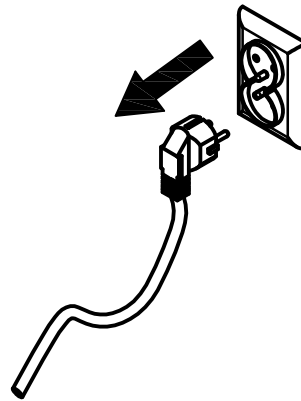
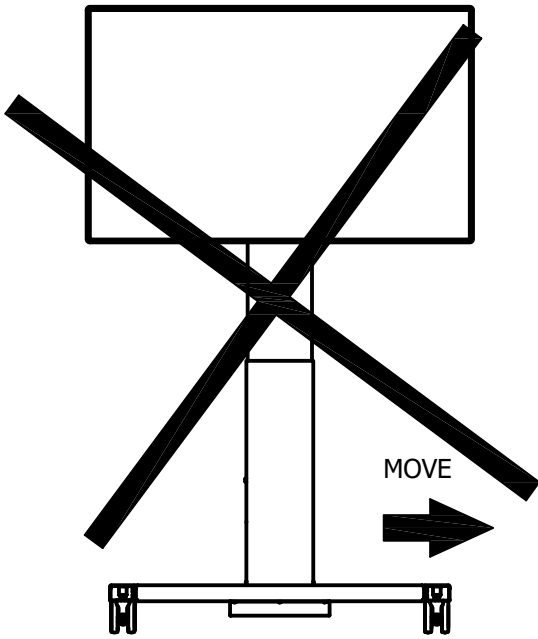

**Disconnect before  
move !!!**

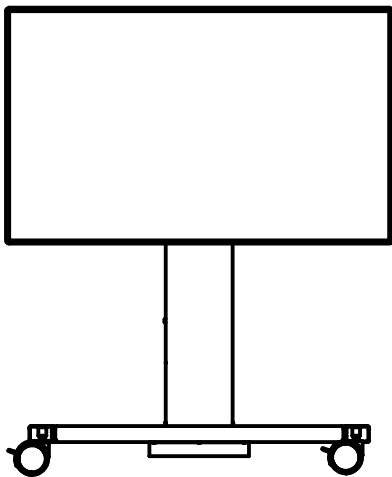

**Transport directions**

**Always use handles  
to transport**

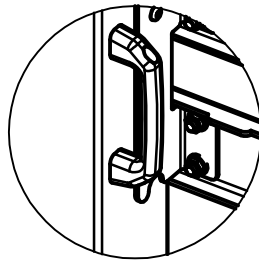

**Max 5°!!!**

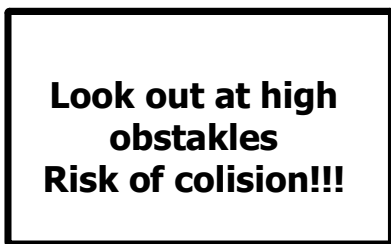
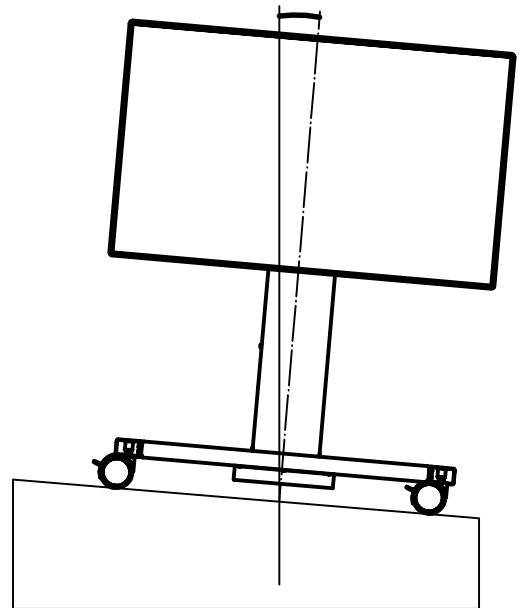

**Look out at high  
obstakles  
Risk of colision!!!**

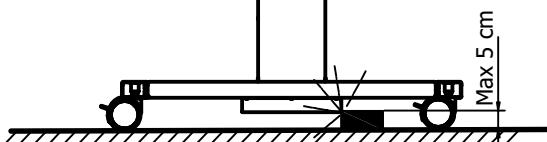

Max 5 cm

Before transporting remember to  
unlock wheel brakes.

**UNLOCK!!!**

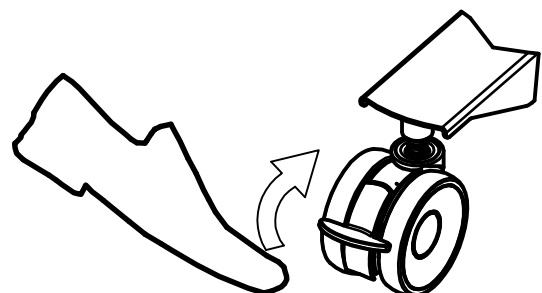

## Removing from palette

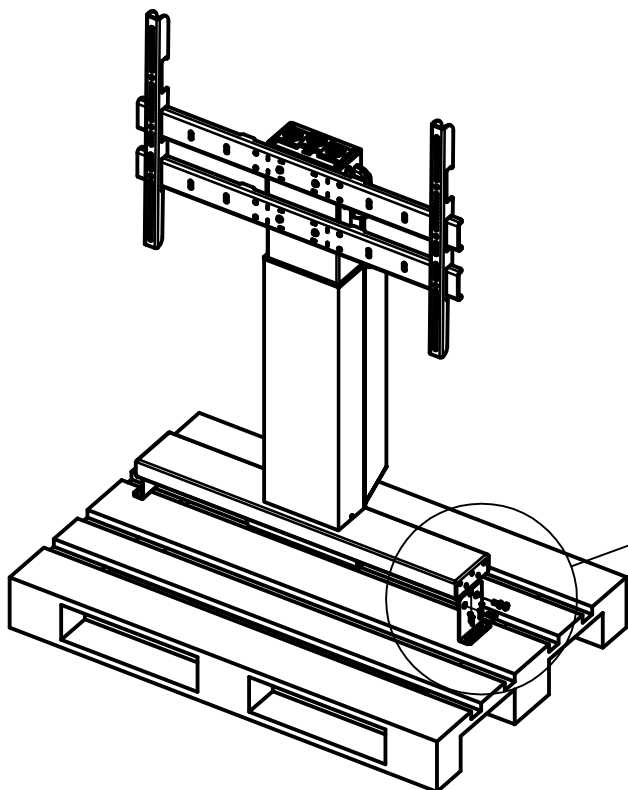

Remove the screws and angle bars and take off the TV lift from the transport palette

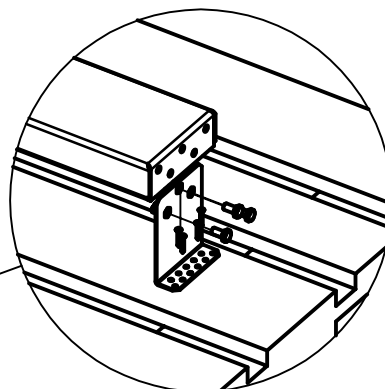

## Legs assembling

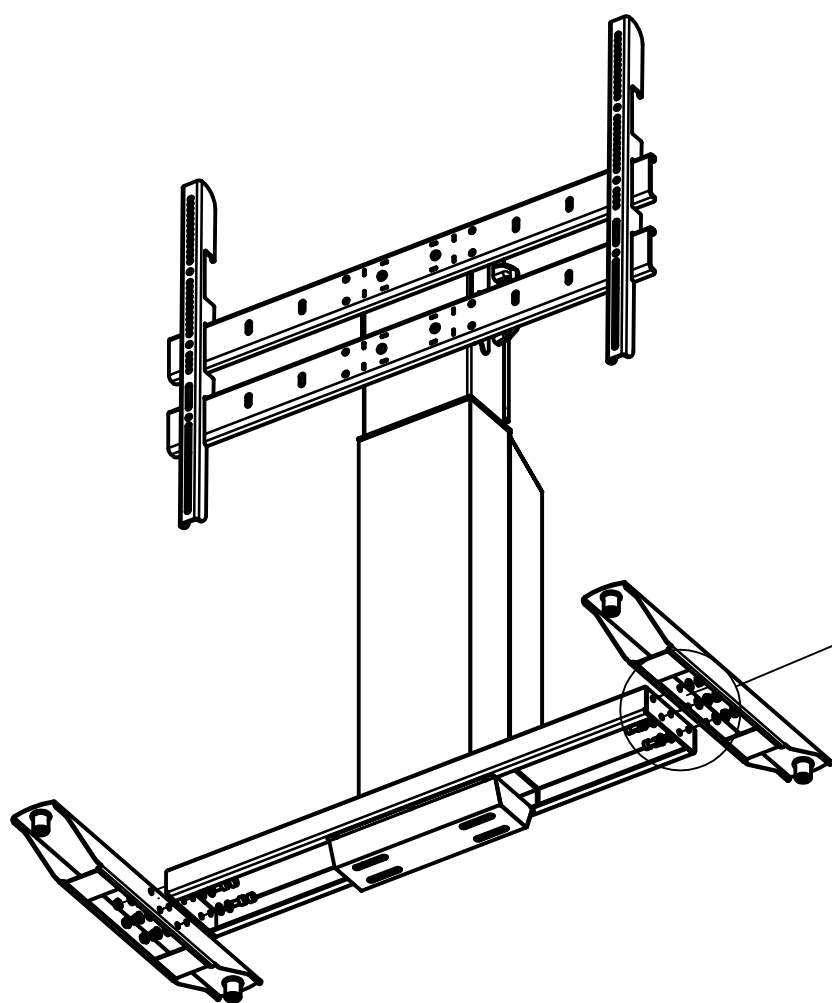

5x ISO10511-M8



5x ISO7089-8

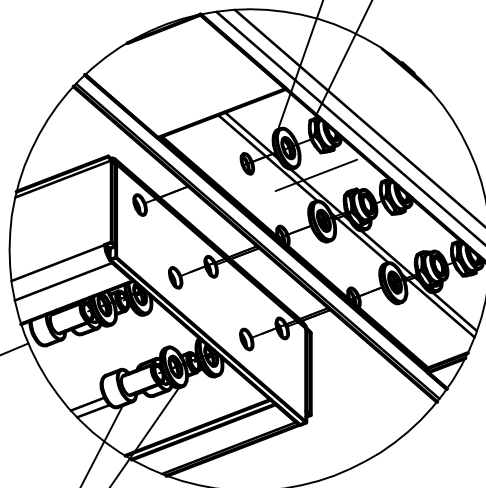

5x ISO7089-8



5x ISO4762-M8x15



## Wheels mounting process

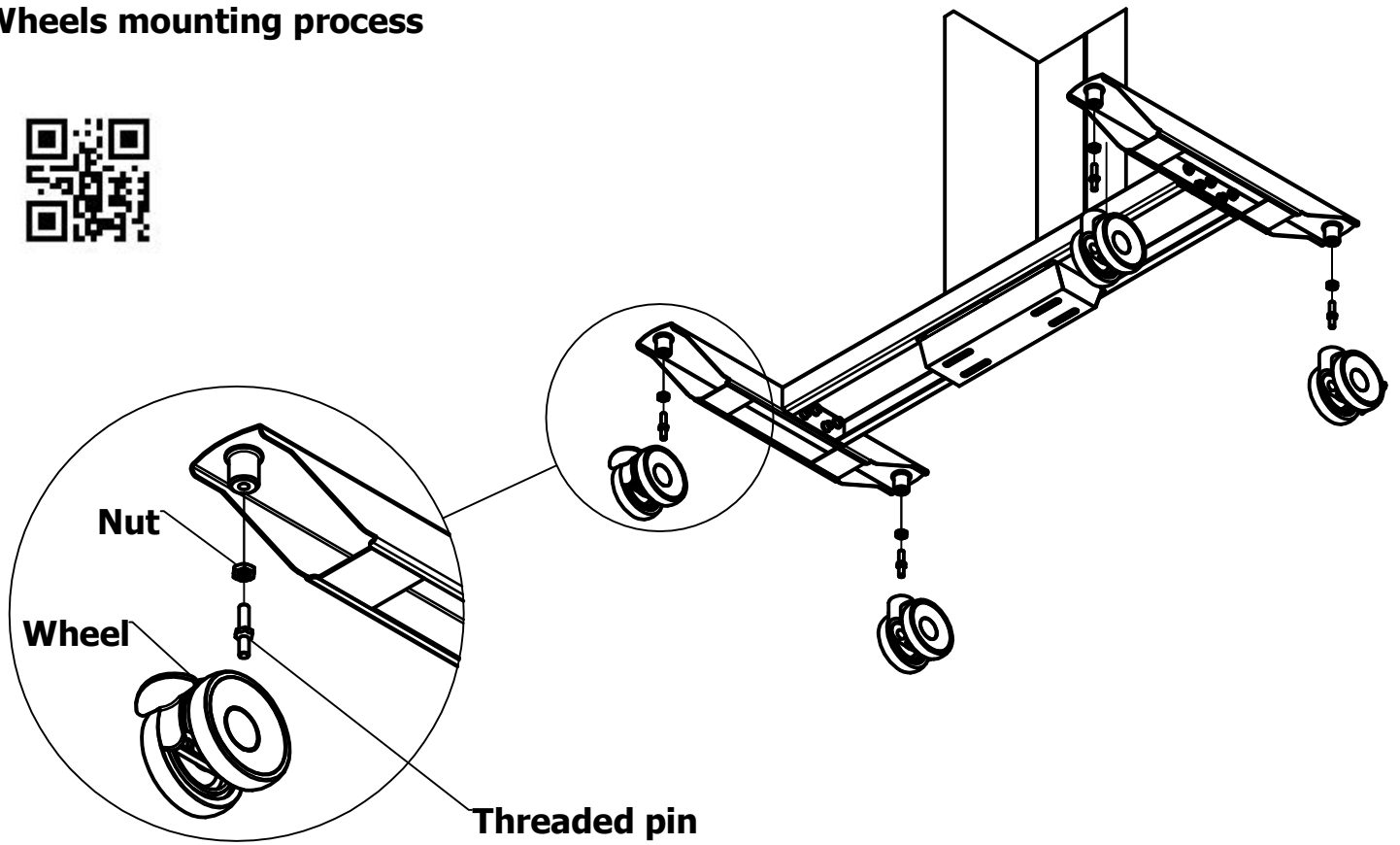

## Lift Leveling

Spanner 17mm

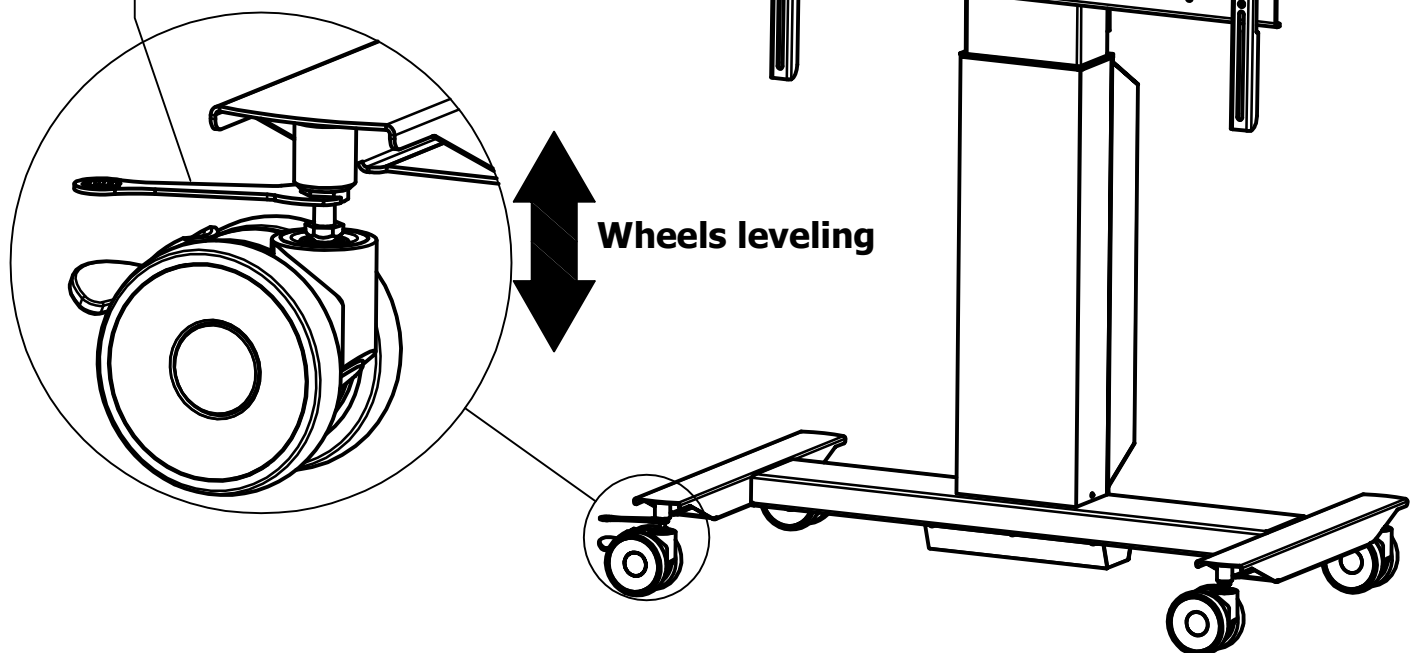

## Screen Mounting process

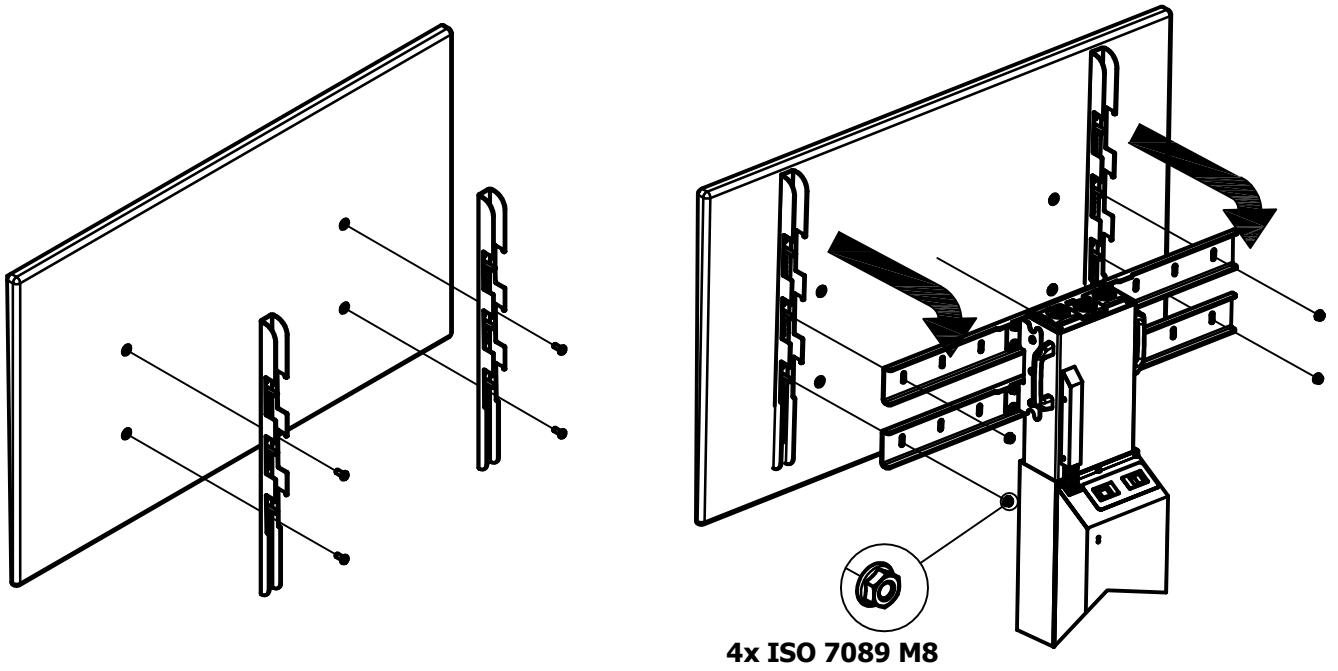

## Remote control holder mounting process

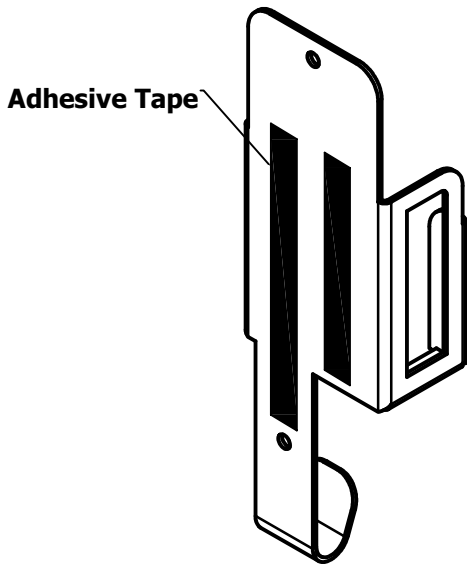

Hang Remote

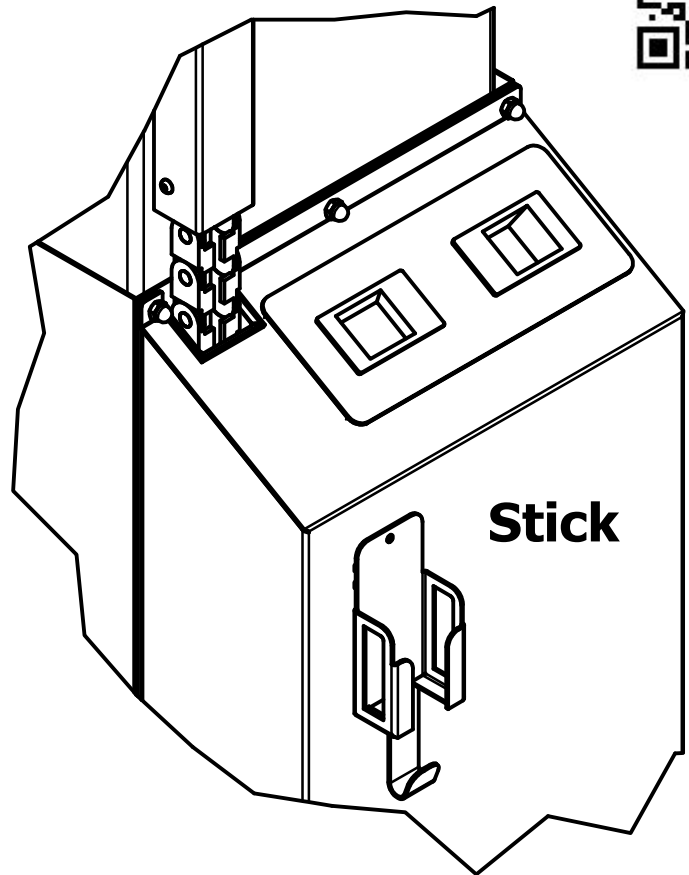

# Lubrication - Recommended once a year



## 1. Lubrication in the down position.

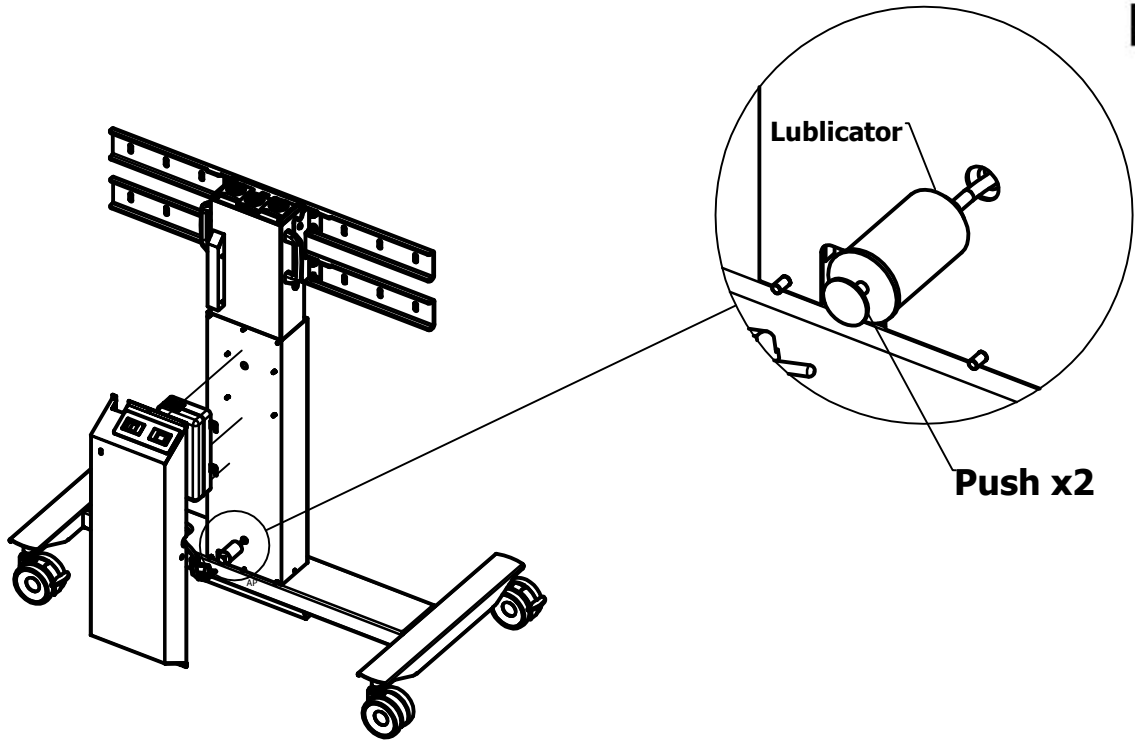

## 2. Lubrication in the top position.

